

# LU

Istruzioni ed avvertenze

Instructions

Instructions

Instrucciones y advertencias

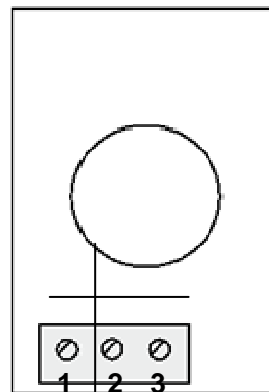
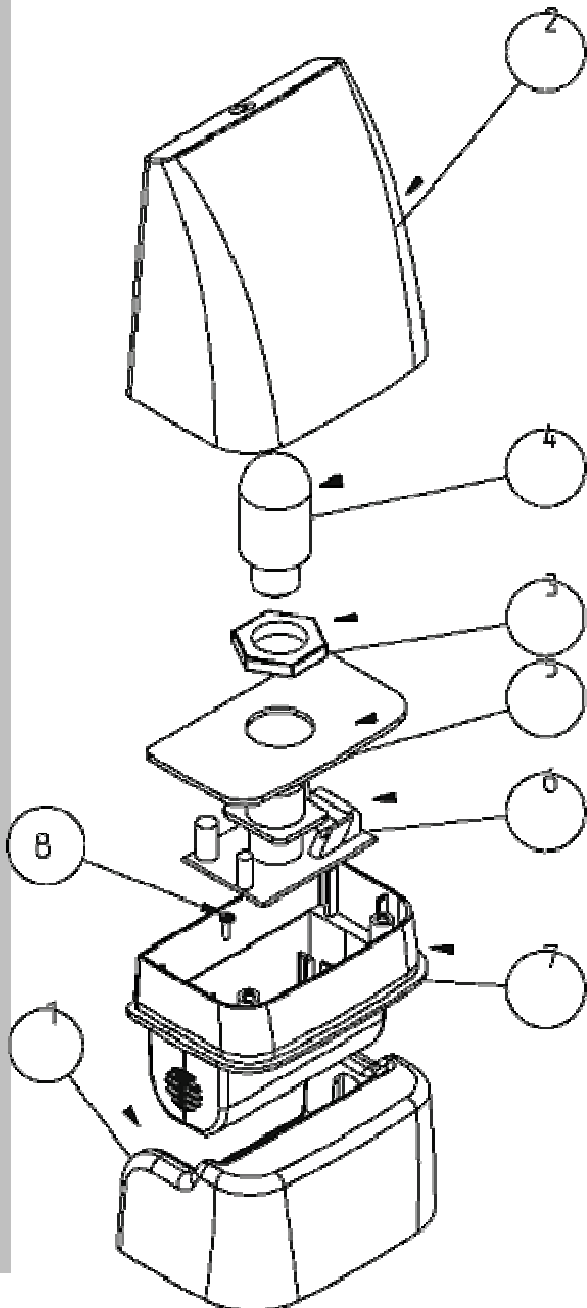

COD	CARD
LUCE-0	R-SCH-LAMP-0
LUCE-0-24VAC	R-SCH-LAMP-0
LUCE-0-24VDC	R-SCH-LAMP-0
LUCE-1	R-SCH-LAMP-1
LUCE-1-24VAC	R-SCH-LAMP-AC
LUCE-1-24VDC	R-SCH-LAMP-DC

1 - 3	LUCE LAMPEGGIANTE CLINKING INTERMITENT CLIGNOTANT INTERMITENT LUZ INTERMITENTE
2 - 3	LUCE FISSA LIGHT FIXED CLIGNOTANT FIXE LUZ FIJA

<b>LUCE-0</b>	luce fissa / light fixed / dignotant fixe / luz fija
<b>LUCE-1</b>	luce lampeggiante / clinking intermitent / clignotant intermitent / luz intermitente

	1	2	3	4	5	6	7	8
Base	Base	Base	Base	Base	Base	Base	Base	Base
Calotta	Cover	Couvercle	Tapa exterior					
Ghiera	Ring	Bague	Tuerca					
Lampadina	Bulb	Ampoule	Bombilla					
Porta scheda elettronica Card holder	Porte-carte électronique	Soporte tarjeta						
Scheda elettronica	Card	Carte électronique	Tarjeta					
Supporto rotante	Rotating stand	Support	Soporte giratorio					
Vite autofilettante	Screw	Vis	Tornillo					

## Caratteristiche generali / Characteristics / Caractéristiques / Características generales



Il segnalatore luminoso LUCE si differenzia in 2 codici distinti: LUCE-0 con scheda elettronica senza lampeggio e LUCE-1 con scheda elettronica a circuito lampeggiante. E' disponibile con 3 differenti tensioni di alimentazione: 230Vac, 24Vdc, 24Vac.  
E' predisposto per lampade da 25W per LUCE 230Vac, o 25W per LUCE 24Vdc, 24Vac  
Il contenitore è a prova di infiltrazione in polycarbonato antiurto non necessita quindi di gabbia di protezione.

The flashing light LUCE is in 2 versions available: LUCE-0 with electronic card without flashing and LUCE-1 with electronic card with flashing. It is in 3 different tensions available: 230Vac, 24Vdc, 24Vac.  
It is arranged for lamps of 25 W for LUCE 230VAC or 25 W for LUCE 24Vdc, 24Vac  
The box is in proof of water penetration in shockproof polycarbonate and it is not required any anti-vandal protection.

Le feu de signalisation LUCE est disponible en 2 versions : LUCE-0 avec carte électronique sans clignote , LUCE -1 avec carte électronique avec clignote. Il est disponible avec différents tensions d'alimentation: 230Vac, 24Vdc, 24Vac.  
Il a aussi la prédisposition pour lampes de 25 W pour LUCE 230Vac ou 25 W pour LUCE 24Vdc, 24Vac  
Le boîtier est à preuve d'infiltration en polycarbonate antichoc et il n'y a pas besoin d'une protection anti-vandale

La lámpara LUCE está disponible en 2 versiones: LUCE-0 con tarjeta electrónica sin intermitencia y LUCE-1 con tarjeta electrónica con intermitencia.  
Disponible en 3 diferentes tensiones de alimentación: 230Vac, 24Vdc, 24Vac.  
Preparada, para lámparas de 25W en la LUCE 230Vac o 25W en la LUCE 24Vdc, 24Vac  
La lámpara está a prueba de golpes, fabricado en polycarbonato antivandálico. No necesitando una jaula de protección.

## Caratteristiche tecniche / Characteristics / Caractéristique technique / Características técnicas

alimentazione / power supply / alimentation / <a href="#">alimentación</a>	Vac	<b>230</b>
potenza / power / puissance / <a href="#">potencia</a>	Watt	<b>40</b>
temperatura d'esercizio / operating temperature / temperature / <a href="#">temperatura de funcionamiento</a>	°C min/Max	<b>-20°C/+60°C EN 600068-2-1EN 600068-2-2</b>
grado di protezione / protection / degré de protection / <a href="#">protección</a>	IP	<b>65 EN 60529</b>
contenitore / cover / boîtier / <a href="#">tapa exterior</a>		<b>polycarbonato / polycarbonate</b>
dimensioni / dimensions / dimensions / <a href="#">dimensiones</a>	mm	<b>b95 x h152/165 x p65</b>

## Dichiarazione CE di conformità / EC Conformity declaration / Déclaration de conformité / Declaración CE de conformidad

Il costruttore / the constructor / le fabricant /  
el fabricante

DICHIARA CHE:  
DECLARES THAT:  
DÉCLARE QUE:  
DECLARA QUE:



nome prodotto: **LUCE-0 / LUCE-1**  
name of the product: **lampeggiante / flashing light /**  
nome produit : **feu de signalisation /**  
nombre de producto: **intermitencia**

**IL PRODOTTO E' CONFORME a quanto previsto dalla direttiva comunitaria:**  
**THE PRODUCT CORRESPONDS to the european directives:**  
**LE PRODUIT EST CONFORME a ce qui est prévu par la directive communautaire:**  
**EL PRODUCTO CORRESPONDE a las directivas europeas:**

98/37/EC (EX 89/392/CEE) 89/336/CEE	DIRETTIVA MACCHINE / MACHINERY DIRECTIVE / DIRECTIVE MACHINE / DIRECTIVA MAQUINARIA DIRETTIVA COMPATIBILITA' ELETTROMAGNETICA (EMC) / EMC ELECTROMAGNETIC COMPATIBILITY DIRECTIVE / DIRECTIVE COMPATIBILITÉ ÉLECTROMAGNÉTIQUE / DIRECTIVA COMPATIBILIDAD ELECTROMAGNÉTICA (EMC)
73/23/CEE - 93/68/CEE	DIRETTIVA BASSA TENSIONE E SUCCESSIVA MODIFICA / LOW VOLTAGE DIRECTIVE AND CONSECUTIVE CHANGES / DIRECTIVE BASSE TENSION ET MODIFICATION SUIVANTS / DIRECTIVA DE BAJA TENSION Y LAS MODIFICACIONES POSTERIORES

Dairago, li 14 giugno 2007

tecnocalubert.com  
calubert@tecnocalubert

L'Amministratore  
Ernestino Bandera



